

EC 205x205x72mm

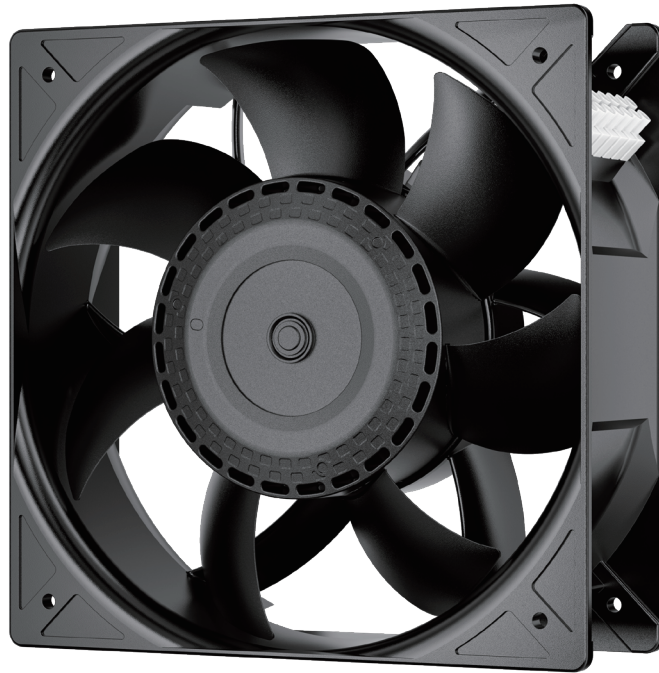

- Innovative, high efficient mixed flow fan
- Jet-engine design, precisely calibrated, aerodynamics refined through CFD optimization
- Eco-watt technology, 3-phase, 6-pole brushless motor
- Certified: CE,UKCA,ETL,SAA,PSE,G-mark

GENERAL SPECIFICATIONS

Insulation:	Class B
Material:	Impeller: Plastic; Frame:Aluminum Alloy
Lead Wire:	UL Type
Mode of operation:	S1
Operation Temperature:	-10°C-70°C, 35%-85%RH
Storage Temperature:	-40°C-80°C, 35%-85%RH
Available Features:	IP68 / PWM / FG&RD / Thermal control / Autoresart / Slow startup

SPECIFICATIONS

Model	Bearing System		Rated Voltage	Frequency	Operation Voltage	Rated Current	Power	Rated Speed	Air Flow	Air Pressure	Noise Level	Weight
	Ball	Sleeve	VAC	Hz	VAC	A	W	RPM	CFM	mmH ₂ O	dBA	g
SE2072HB	●		115/230	50/60	98~135	2.02/1.10	145	3500	932.9	41.1	73.1	1880
SE2072MB	●					1.60/0.80	95	3000	801.7	30.7	69.4	
SE2072LB	●					1.0/0.50	60	2500	644.1	21.2	65.0	

DIMENSIONS DRAWIN

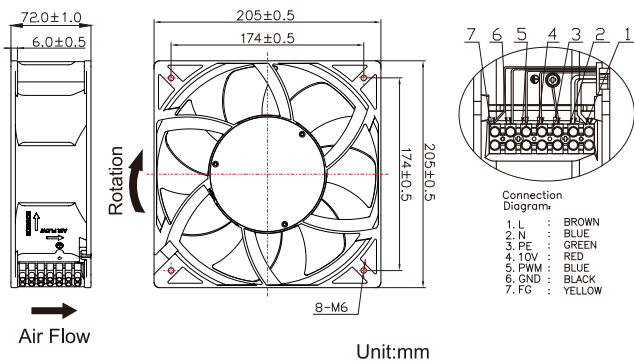

P&Q CURVE(AT RATED VOLTAGE)

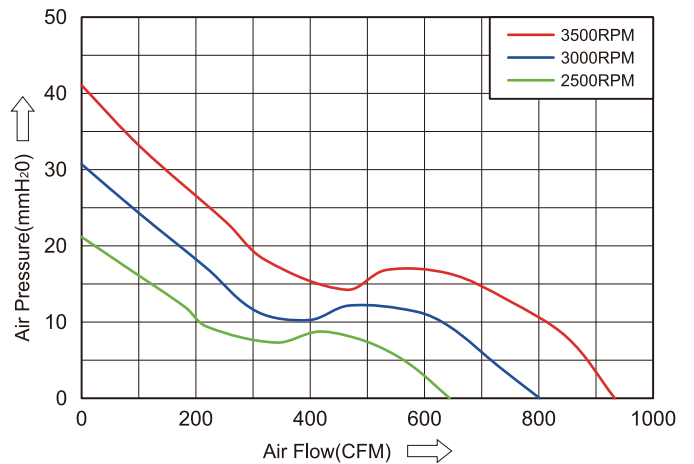

Note:

- *All readings are typical values at rated voltage.
- *The noise value is the measured value at the distance of 1 meter from the fan inlet
- *Specifications are subject to change without prior notice.
- * "X" in model list can be B, S, and C, meaning Dual Ball Bearing, Sleeve Bearing and 1 Ball 1 Sleeve Bearing